

49S系列/49S Series

CH49S-12.000M120D2-NB

(料号参考下页选型指南)

Pb Free

RoHS Compliant
2002/95/EC

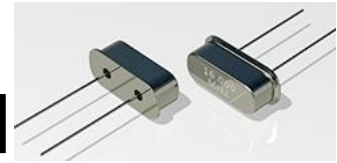

※ 应用及特点 Application & Features

- 电脑、网卡、通讯 Computer, Modem, Communications
- 蓝牙、无线 Bluetooth, Wireless
- 自动控制设备及其它 Automotive Equipment at Other
- 金属封装尺寸: 11.05×4.65×3.38mm Metal Package

※ 电气参数 Electrical Specification

项 目 Item	参数 Parameter
频率范围 Frequency Range	3.200 to 100.000MHz
调整频差 Frequency Tolerance) (ΔF)(at25°C)	± 10 to ± 50 ppm
温度频差 Frequency Drift)	± 10 to ± 50 ppm
工作温度 Operating Temperature Range	-20 to 70 / -40 to 85 °C
储存温度 Storage Temperature Range	-40 to 85 °C
负载电容 Load Capacitance , (CL)	Suggested by customer
激励功率 Drive Level)	10 μ W(500 μ W Max)
静态电容 Shunt Capacitance ,(C0)	7.0pF Max
老化率 Aging at 25 °C	± 5 ppm/year Max
绝缘阻抗 Insulation Resistance (Rs)	500M Ω Min at100Vdc

※ 等效电阻和振荡模式 Equivalent Series Resistance (ESR) and Mode of Oscillation

频率范围 Frequency Range (MHz)	等效阻抗 ESR(Ω)	振荡模式 Mode of Oscillation
3.200 - 3.999 MHz	150 Max	基频 AT Fund
4.000 - 4.999 MHz	120 Max	基频 AT Fund
5.000 - 6.000 MHz	100 Max	基频 AT Fund
6.000 - 7.000 MHz	80 Max	基频 AT Fund
7.000 - 10.000 MHz	60 Max	基频 AT Fund
10.000 - 14.000 MHz	50 Max	基频 AT Fund
14.000 - 20.000 MHz	40 Max	基频 AT Fund
20.000 - 40.000 MHz	30/40(BT Cut)Max	基频 BT Fund
≥ 30.000 MHz	80 Max	三次泛音 3RD

※ 外形尺寸及印字 Mechanical Dimensions and Marking

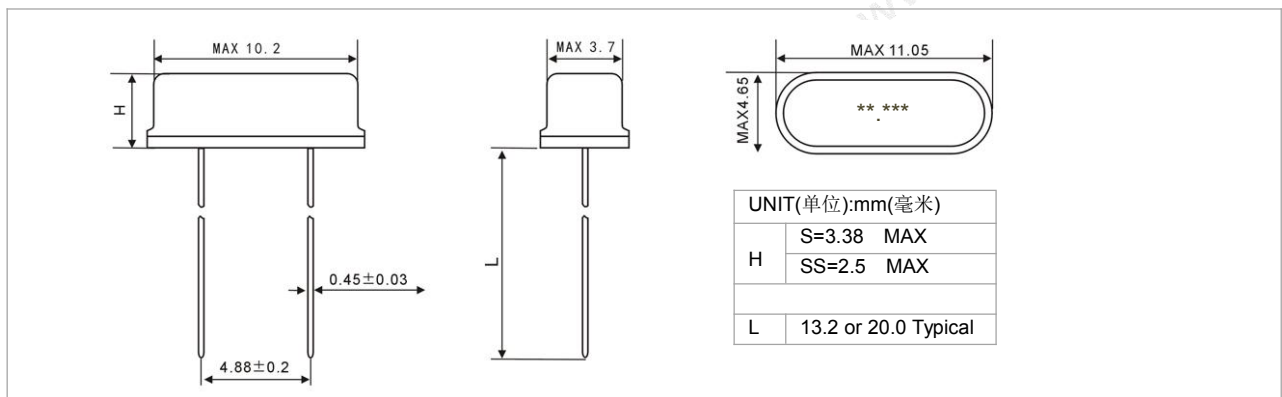

※ 应用环境标准 Environmental /Mechanical SPEC

项目 Item	参数 Parameter	回流焊条件 Reflow Condition
耐冲击性 Shock Resistance	跌落测试:75cm 高度,跌落三次至硬木板 Drop from Height 75cm to hard wooded board 3 times	 <p>CYCLE TIME:200sec Max.</p>
焊接条件 Solder Condition	引线焊接时,烙铁最高温度 260 度,焊接时间最长 10 秒 Lead wire should be soldered with 10S with the iron heated to a tip temperature 260°C (Max)	

※ 选型指南 Part Number Guide

CH		49S		—		12.000M		—		1		20		D2		N		B		
CHXTAL	型号 Table1	频率 Frequency Range	振荡模式 1: Fund 3: 3RD 5: 5thovertone	负载电容(PF) Load Capacitance																包装方式 B: 散包 Bulk T: 编带 Tape
																				附加加工 N: 普通 Normal C: 切脚 Lead Cutting G: 弯脚 Gull Wing J: 套管 Jacket I: 绝缘垫片 Insulator
																				温度特性 Table2

※ Table1 型号/Type

A	B	C	D	E	F	G	H		
49S	49SS	49S3	49SX	49SSX	49S3X	49S4X	M49SX		

※ Table2 温度特性及频差/Frequency stability at Temperature Range

温度特性及频差 Frequency stability @Temperature Range							
	Temp (°C)	-10~60	-20~70	-20~85	-40~85	-40~105	-40~125
Stability (ppm)		A	B	C	D	E	F
±10	1	*	*				
±20	2	*	*	*	*		
±30	3	*	*	*	*	*	
±50	5	*	*	*	*	*	*