

ZTA系列/ZTA Series

CHZTA-3.58MGK3-NB

(料号参考下页选型指南)

Exempted by
RoHs

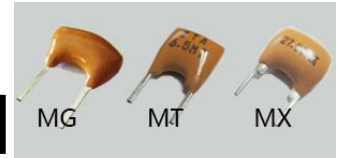

※ 应用及特点 Application & Features

- 插脚式高频谐振器 Plug in type high frequency resonator
- 鼠标键盘、电话机、电视机、录像机、仪器仪表、计算机、电子玩具、遥控器等... Mouse keyboard, telephone, TV, video recorder, instrument, computer, electronic toy, remote control, etc.

※ 电气参数 Electrical Specification

型号 Part NO.	频率范围 Freq Range (MHZ)	频率精度 Freq Accuracy (25℃)(%)	温度稳定性 Stability in TEMP (-20~+80℃)(%)	工作温度 Operating TEMP (℃)	老化率(10年) Aging For Ten Year (%)
ZTA□MG	1.79~6.00	±0.3~±0.5	±0.3	-25~+85	±0.3
ZTA□MT	6.00~13.00	±0.3~±0.5	±0.3	-25~+85	±0.3
ZTA□MX	12.00~60.00	±0.3~±0.5	±0.3	-25~+85	±0.3

※ 测试电路(用于 MOS IC) TEST CIRCUIT FOR MOS IC

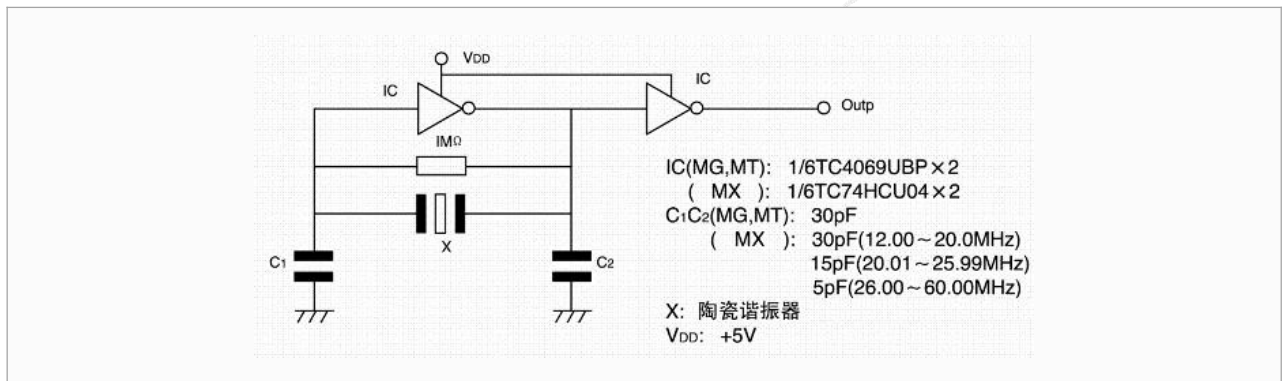

※ 外形尺寸及印字 Mechanical Dimensions and Marking

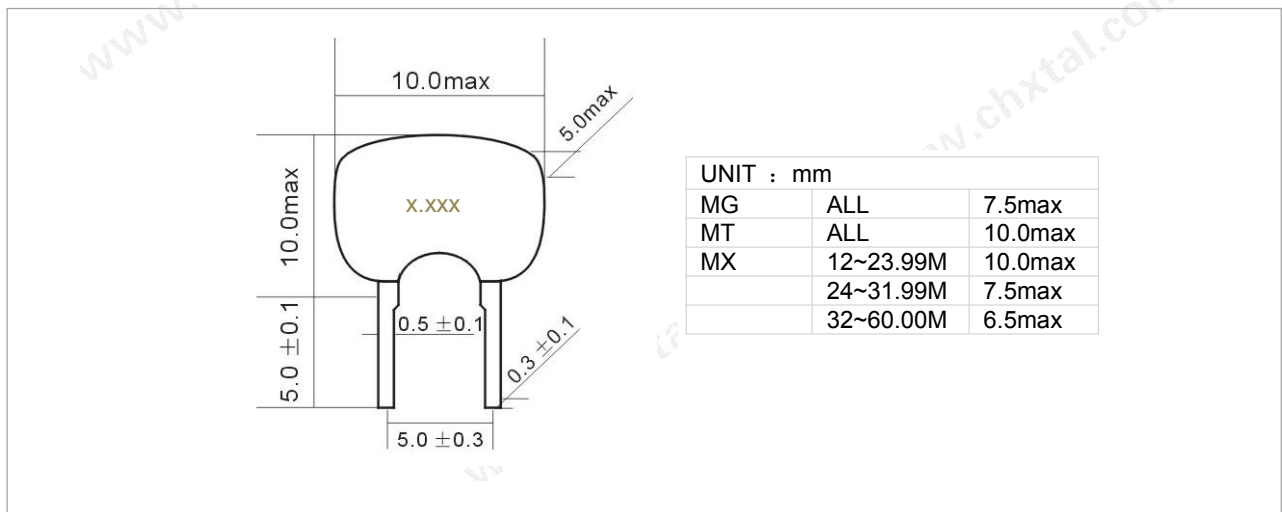

※ 应用环境标准 Environmental /Mechanical SPEC

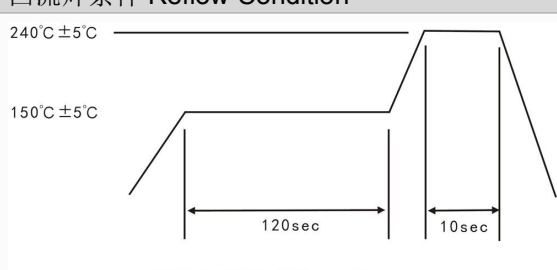
项目 Item	参数 Parameter	回流焊条件 Reflow Condition
耐冲击性 Shock Resistance	跌落测试:75cm 高度,跌落三次至硬木板 Drop from Height 75cm to hard wooded board 3 times	 <p>CYCLE TIME: 200sec Max.</p>
焊接条件 Solder Condition	引线焊接时,烙铁最高温度 240 度,焊接时间最长 10 秒 Lead wire should be soldered with 10S with the iron heated to a tip temperature 240°C (Max)	

※ 选型指南 Part Number Guide

CH	ZTA	—	3.58MG	K3	—	N	B
CHXTAL	型号 Table1	频率 Frequency	频率精度 K3: ±0.3 / 0.3% K5: ±0.5 / 0.5%			附加加工 N: 普通 Normal C: 切脚 Lead Cutting G: 弯脚 Gull Wing	包装方式 B: 散包 Bulk T: 编带 Tape

※ Table1 型号/Type

A	B	C	D	E	F	G	H
ZTA□MG	ZTA□MT	ZTA□MX	ZTT□MG	ZTT□MT	ZTT□MX		