

ZTACV□MX系列 / ZTACV□MX Series

☑ CHZTACV-16.00MXK3-NT

(料号参考下页选型指南)



※ 应用及特点 Application & Features

- 片式陶瓷谐振器 Chip Ceramic Resonator
- 适用于鼠标键盘、电话机、电视机、录像机、仪器仪表、计算机、电子玩具、遥控器等... Mouse keyboard, telephone, TV, video recorder, instrument, computer, electronic toy, remote control, etc.

※ 电气参数 Electrical Specification

项目 Item	参数 Parameter
中心频率 Center Freq(MHz)	16.00
频率范围 Freq Range(MHZ)	13.01~60.00
频率精度 Freq Accuracy(25℃)(%)	±0.3~±0.5
温度稳定性 Stability in TEMP(-20~+80℃)(%)	±0.3
工作温度 Operating TEMP(℃)	-25~+85
老化率(10年) Aging For Ten Year(%)	±0.3

※ 测试电路(用于 MOS IC) TEST CIRCUIT FOR MOS IC

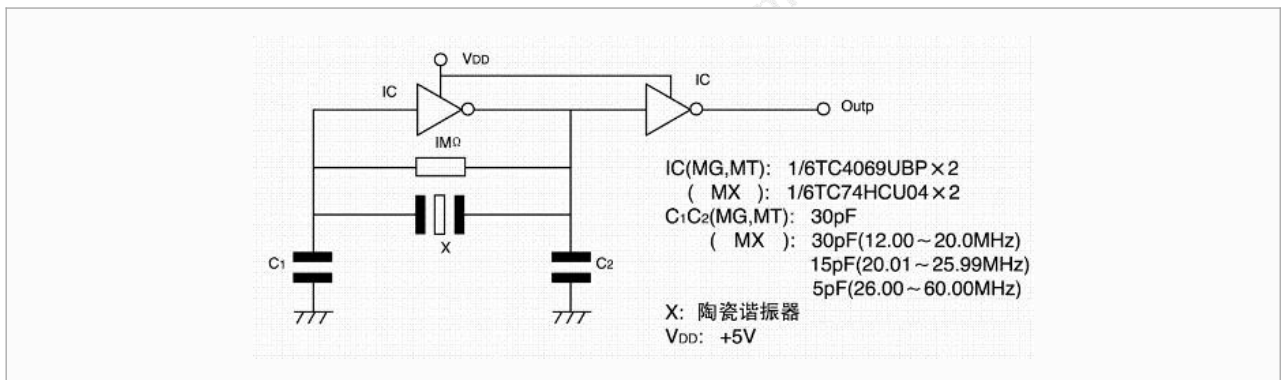

※ 外形尺寸及印字 Mechanical Dimensions and Marking

unit: mm	
1	输入 Input
2	输出 Output

型号 Part No.	L	W	H	P1	P2	T
ZTACV□MX	3.7±0.2	3.1±0.2	(1.0+A)±0.2	0.9±0.2	0.7±0.2	3.0±0.2

※ 应用环境标准 Environmental /Mechanical SPEC

项目 Item	参数 Parameter	回流焊条件 Reflow Condition
耐冲击性 Shock Resistance	跌落测试:75cm 高度,跌落三次至硬木板 Drop from Height 75cm to hard wooded board 3 times	<p>CYCLE TIME: 200sec Max.</p>
焊接条件 Solder Condition	引线焊接时,烙铁最高温度 240 度, 焊接时间最长 10 秒 Lead wire should be soldered with 10S with the iron heated to a tip temperature 240°C (Max)	

※ 选型指南 Part Number Guide

CH	ZTACV	—	16.00MX	K3	—	N	T
CHXTAL	型号 Table1	频率 Frequency	频率精度 K3: ±0.3 / 0.3% K5: ±0.5 / 0.5%	附加加工 N: 普通 Normal	包装方式 B: 散包 Bulk T: 编带 Tape		

※ Table1 型号/Type

A	B	C	D	E	
ZTACC□MG	ZTTCC□MG	ZTACR□MG	ZTTCR□MG	ZTTCE□MG	
F	G	H	I	J	K
ZTACS□MT	ZTTCS□MT	ZTACV□MT	ZTTCV□MT	ZTACS□MX	ZTTCS□MX
L	M	N	O		
ZTACV□MX	ZTTCV□MX	ZTACW□MX	ZTTCW□MX		