



SPECIFICATION FOR APPROVAL

CUSTOMER	:	_____
PRODUCT TYPE	:	SMD SEAM SEALING XTAL 5.0*3.2
NOMINAL FREQ.	:	25.000000MHz
TXC P/N	:	7B25000023
REVISION	:	A4
CUSTOMER P/N	:	_____
PM / SALES	:	_____
DATE	:	_____
CUSTOMER SIGNATURE & Date	:	_____

- (1) TXC requires one copy returned with signature and title of authorized individual that signifies acceptance of the attached specifications.
- (2) Orders received and accepted by TXC after return of signed copy of specification will be produced per these specifications.
- (3) Any changes to these specifications must be agreed upon by both parties and new revision of the Product Specification Sheet will be issued.
- (4) Any issuance of purchase order prior to consigning back the Approval page of "Specification Sheets" from customers will be regarded as the agreement on the contents of these specifications.

Attachment: Product Specification Sheet

- 1
- 2
- 3
- 4
- 5

RoHS Compliant



PRODUCT SPECIFICATION SHEET

PRODUCT TYPE : SMD SEAM SEALING XTAL 5.0*3.2

NOMINAL FREQ. : 25.000000MHz

TXC P/N : 7B25000023

REVISION : A4

PE/RD	QA	MFG
<i>Scott Chen</i>	<i>Randy Cheng</i>	<i>陳錦亭</i>
<i>21-Jun-06</i>	<i>21-Jun-06</i>	<i>21-Jun-06</i>

NOTE:

- (1)Lead Free Products are "Directive 2002/95/EC of The European Parliament of 27 January 2003 on the restriction of the use of certain hazardous substances (RoHS) in electrical and electronic equipment" Compliant (Attachment: SGS Test Report).
- (2)Revision "Sx" is for engineering samples only. PE/RD's approval required.
- (3)Revision "Ax" is production ready. PE, QA and MFG's approval required

RoHS Compliant

Rev	Revise page	Revise contents	Date	Ref.No.	Reviser
A1	N/A	Initial released	16-Mar-05	N/A	Yachuan Miao
A2	3	Suggested Reflow Profile Change	27-Mar-05	ECN-05P050501	Yachuan Miao
A3	1	客戶回簽頁新增: Any issuance of purchase order prior to consigning back the Approval page of "Specification Sheets" from customers will be regarded as the agreement on the contents of these specifications.	2-Aug-05	DCN-05P062302	Yachuan Miao
	3,4	圖面角位修正	25-Aug-05	ECN-05P081002	Yachuan Miao
	4	STRUCTURE ILLUSTRATION 原物料名稱異動		ECN-05P081601	
A4	-	Document version chang C to D	21-Jun-06	DCN-06P030701	Yachuan Miao

ELECTRICAL SPECIFICATIONS

Standard atmospheric conditions

Unless otherwise specified, the standard range of atmospheric conditions for making measurement and tests are as follow:

- Ambient temperature : 25±5
- Relative humidity : 40%~70%

If there is any doubt about the results, measurement shall be made within the following limits:

- Ambient temperature : 25±3
- Relative humidity : 40%~70%

Measure equipment

Electrical characteristics measured by HP E5100A or equivalent.

Crystal cutting type

The crystal is using AT CUT (thickness shear mode).

Unit Weight:

0.046±0.001 g/pcs

	Parameters	SYM.	Electrical Spec.				Notes
			MIN	TYPE	MAX	UNITS	
1	Nominal Frequency	FL	25.000000			MHz	-
2	Oscillation Mode	-	Fundamental			-	-
3	Load Capacitance	CL	18			pF	-
4	Frequency Tolerance	-	±30			ppm	at 25 ± 3
5	Frequency Tolerance	-	±30			ppm	Over Operating Temp. Range (Reference 25)
6	Operating Temperature	-	-20	~	70		-
7	Aging	-	±2			ppm	1st Year
8	Drive Level	DL	-	100	-	uW	-
9	Effective Resistance Rr	Rr	-	-	40	Ω	-
10	Shunt Capacitance C0	C0	-	-	5	pF	-
11	Insulation Resistance	-	500	-	-	MΩ	at DC 100V
12	Storage Temperature Range	-	-40	~	125		-

DIMENSIONS

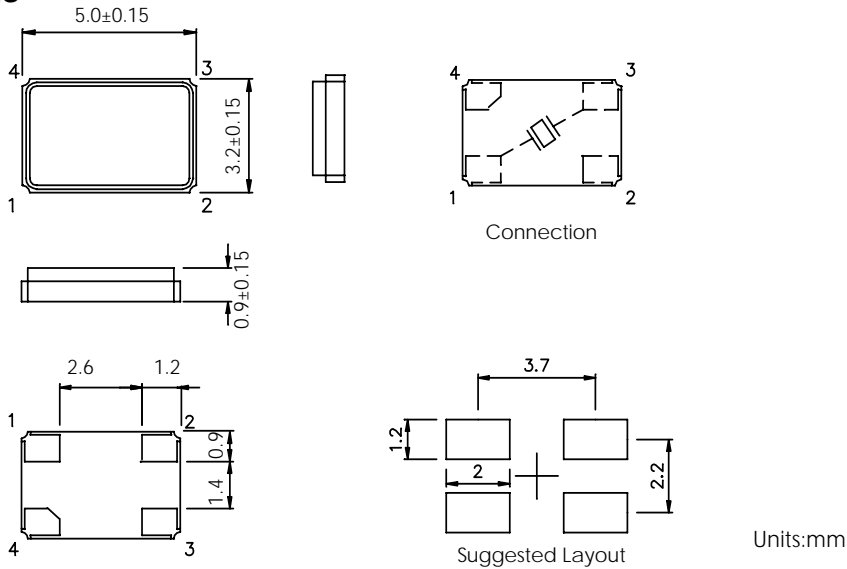

MARKING

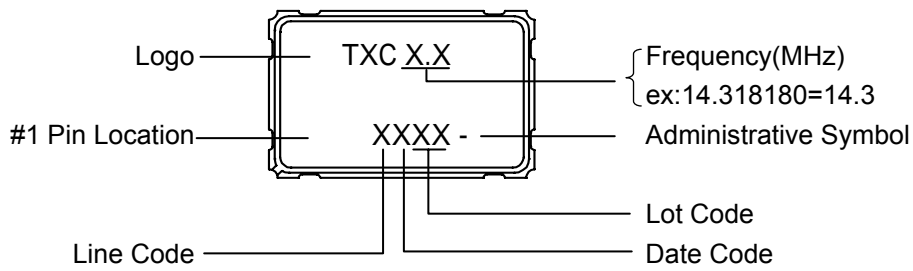

Production location: China or Taiwan

Date Code

YEAR					MONTH											
					JAN	FEB	MAR	APR	MAY	JUN	JUL	AUG	SEP	OCT	NOV	DEC
2001	2005	2009	2013	2017	A	B	C	D	E	F	G	H	J	K	L	M
2002	2006	2010	2014	2018	N	P	Q	R	S	T	U	V	W	X	Y	Z
2003	2007	2011	2015	2019	a	b	c	d	e	f	g	h	j	k	l	m
2004	2008	2012	2016	2020	n	p	q	r	s	t	u	v	w	x	y	z

This date code will be cycled every four years

SUGGESTED REFLOW PROFILE

Total time : 200 sec. Max.

Solder melting point :220

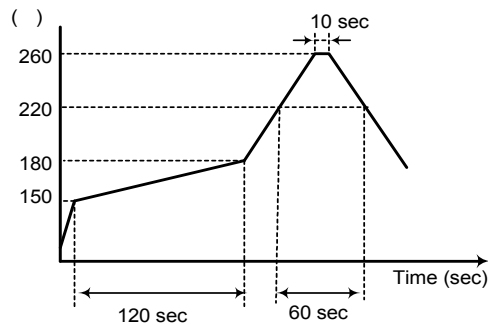

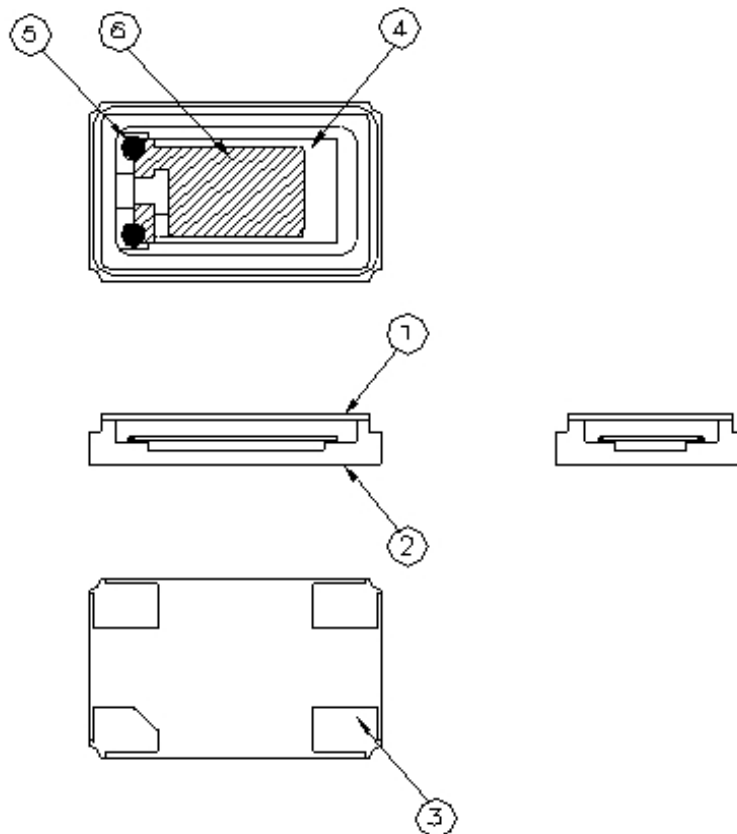
STRUCTURE ILLUSTRATION

NO	COMPONENTS	MATERIALS	QTY	FINISH/SPECIFICATIONS
1	Lid	Kovar (Fe/Co/Ni)	1	-
2	Base(Package)	Ceramic (Al ₂ O ₃) + Kovar (Fe/Co/Ni)+ Ag/Cu	1	Color black
3	PAD	Au	4	Tungsten metalize + Ni plating + Au plating
4	Crystal blank	SiO ₂	1	-
5	Conductive adhesive	Ag	4	Silicon resin
6	Electrode	Ag + Cr	2	-

PACKING : (EIA-481-2)

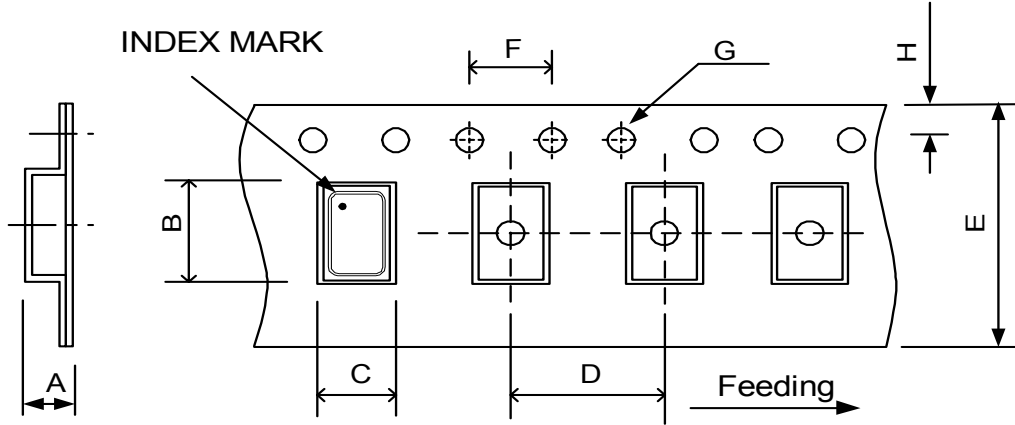

DIMENSIONS	A	B	C	D	E	F	G	H	(UNIT : mm)
	1.40	5.40	3.60	8.00	12.00	4.00	1.55	1.75	

REMARK :

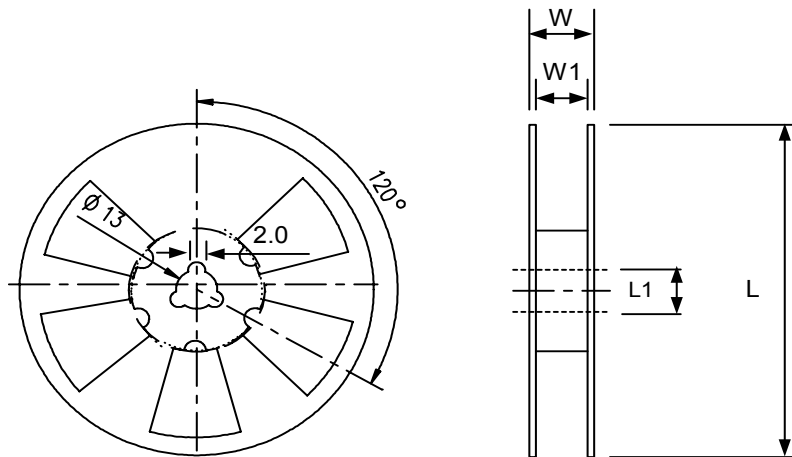
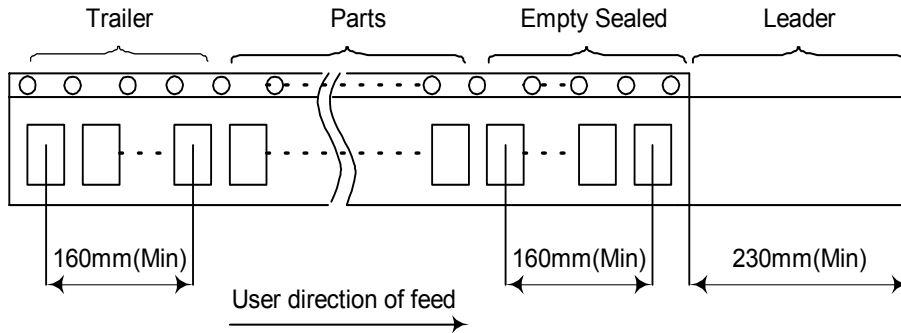

DIMENSIONS	L	L1	W	W1	pcs / Reel (UNIT : mm)
	180	13	16.5	12	Standard Reel Quantity is 1,000 pcs per reel

RELIABILITY SPECIFICATIONS

1.Mechanical Endurance

No.	Test Item	Test Methods	REF.DOC
1.1	Drop Test	75 cm height,3 times on concrete floor .	JIS C6701
1.2	Mechanical Shock	Device are shocked to half sine wave (1000 G) three mutually perpendicular axes each 3 times. 0.5m sec. duration time	MIL-STD-202F
1.3	Vibration	Frequency range 10 ~ 2000 Hz Amplitude 1.52 mm/20G Sweep time 20 minute Perpendicular axes each test time 4 hours (Total test time 12 hours)	MIL-STD-883E
1.4	Gross Leak	Standard Sample For Automatic Gross Leak Detector, Test Pressure: 2Kg / cm ²	MIL-STD-883E
1.5	Fine Leak	Helium Bombing 4.5 Kgf / cm ² for 2 hr	
1.6	Solderability	Temperature 260 ± 5 Immersing depth 0.5 mm minimum Immersion time 5 ± 1 seconds Flux Rosin resin methyl alcohol solvent (1 : 4)	MIL-STD-883E

2.Environmental Endurance

No.	Test Item	Test Methods	REF. DOC
2.1	Resistance To Soldering Heat	Pre-heat temperature 125 Pre-heat time 60 ~ 120 sec. Test temperature 260 ± 5 Test time 10 ± 1 sec.	MIL-STD-202F
2.2	High Temp. Storage	+ 125 ± 3 for 1000 ± 12 hours	MIL-STD-883E
2.3	Low Temp. Storage	- 40 ± 3 for 1000 ± 12 hours	
2.4	Thermal Shock	Total 100 cycles of the following temperature cycle 	MIL-STD-883E
2.5	High Temp & Humidity	85 ± 3 , RH 85% , 1000Hrs	JIS C5023
2.6	Pressure Cooker Storage	121 ± 3 , RH100% , 2 bar , 240Hrs	JIS C6701