



**TXC CORPORATION**

4F, NO. 16, Sec. 2 Chung Yang S Rd., Peitou, Taipei, Taiwan.

TEL : 886-2-2894-1202 , 886-2-2895-2201 FAX : 886-2-2894-1206 , 886-2-2895-6207

www.txccorp.com

# SPECIFICATION FOR APPROVAL

CUSTOMER : \_\_\_\_\_

PRODUCT TYPE : SMD Crystal 1.6×1.2  
\_\_\_\_\_

NOMINAL FREQ. : 26.000000MHz  
\_\_\_\_\_

TXC P/N : 8Q26000003  
\_\_\_\_\_

REVISION : A1  
\_\_\_\_\_

CUSTOMER P/N : \_\_\_\_\_

PM / SALES : \_\_\_\_\_

DATE : \_\_\_\_\_

CUSTOMER SIGNATURE & Date  
\_\_\_\_\_  
\_\_\_\_\_

- (1) TXC requires one copy returned with signature and title of authorized individual that signifies acceptance of the attached specifications.
- (2) Orders received and accepted by TXC after return of signed copy of specification will be produced per these specifications.
- (3) Any changes to these specifications must be agreed upon by both parties and new revision of the Product Specification Sheet will be issued.
- (4) Any issuance of purchase order prior to consigning back the Approval page of "Specification Sheets" from customers will be regarded as the agreement on the contents of these specifications.

Attachment: Product Specification Sheet

- 1
- 2
- 3
- 4
- 5

**RoHS Compliant**



**TXC CORPORATION**

4F, NO. 16, Sec. 2 Chung Yang S Rd., Peitou, Taipei, Taiwan.

TEL : 886-2-2894-1202 , 886-2-2895-2201 FAX : 886-2-2894-1206 , 886-2-2895-6207

www.txccorp.com

# PRODUCT SPECIFICATION SHEET

PRODUCT TYPE : SMD Crystal 1.6×1.2

NOMINAL FREQ. : 26.000000MHz

TXC P/N : 8Q26000003

REVISION : A1

PE/RD	QA	MFG
<i>Mike Chiu</i> Mike Chiu	<i>Alex Huang</i> Alex Huang	<i>Rick Lo</i> Rick Lo
<i>5/3/2013</i>	<i>5/3</i>	<i>5/6/2013</i>

**NOTE:**

- (1)Lead Free Products are "Directive 2002/95/EC of The European Parliament of 27 January 2003 on the restriction of the use of certain hazardous substances (RoHS) in electrical and electronic equipment" Compliant (Attachment: SGS Test Report).
- (2)Revision "Sx" is for engineering samples only. PE/RD's approval required.
- (3)Revision "Ax" is production ready. PE, QA and MFG's approval required

**RoHS Compliant**



<u>Rev</u>	<u>Revise page</u>	<u>Revise contents</u>	<u>Date</u>	<u>Ref.No.</u>	<u>Reviser</u>
A1	N/A	Initial released	30-Apr-13	N/A	Yachuan Miao

## ■ ELECTRICAL SPECIFICATIONS

### Standard atmospheric conditions

Unless otherwise specified, the standard range of atmospheric conditions for making measurement and tests are as follow:

Ambient temperature :  $25 \pm 10^{\circ}\text{C}$   
 Relative humidity : 40%~70%

If there is any doubt about the results, measurement shall be made within the following limits:

Ambient temperature :  $25 \pm 3^{\circ}\text{C}$   
 Relative humidity : 40%~70%

### Measure equipment

Electrical characteristics measured by HP E5100A or equivalent.

### Crystal cutting type

The crystal is using AT CUT (thickness shear mode).

### Unit Weight:

0.0029 $\pm$ 0.0010 g/pcs

	Parameters	Symbol	Electrical Spec.				Notes
			Min.	Typ.	Max.	Units	
1	Nominal Frequency	FL	26.000000			MHz	-
2	Oscillation Mode	-	Fundamental			-	-
3	Load Capacitance	CL	12			pF	-
4	Frequency Tolerance	-	$\pm 10$			ppm	at $25^{\circ}\text{C} \pm 3^{\circ}\text{C}$
5	Frequency Stability	-	$\pm 15$			ppm	Over Operating Temp. Range (Reference $25^{\circ}\text{C}$ )
6	Operating Temperature	-	-30	~	85	$^{\circ}\text{C}$	-
7	Aging	-	$\pm 2$			ppm	1st Year
8	Drive Level	DL	-	100	-	uW	-
9	Equivalent Series Resistance	ESR	-	-	80	$\Omega$	-
10	Insulation Resistance	-	500	-	-	M $\Omega$	at DC 100V
11	Storage Temperature Range	-	-40	~	85	$^{\circ}\text{C}$	-

**■ DIMENSIONS**

(Unit:mm)

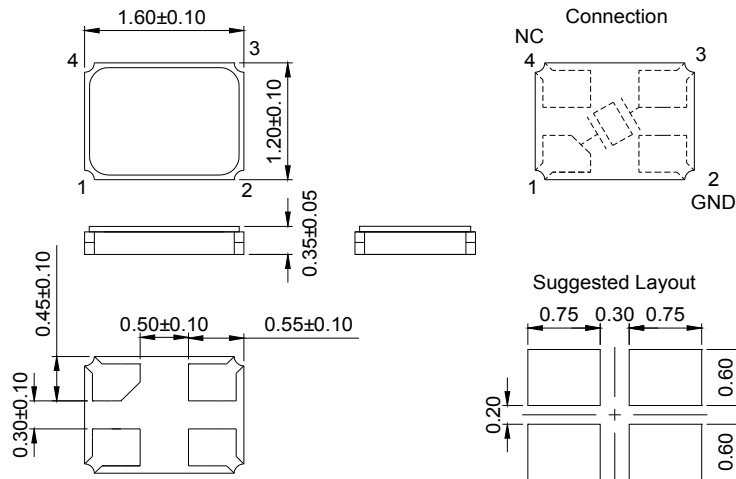

**■ MARKING**

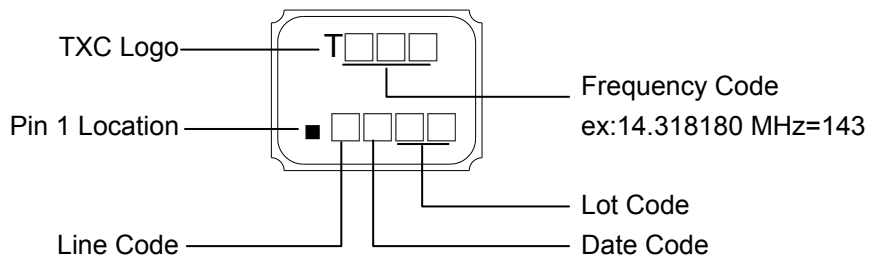

**Date Code:**

YEAR \ MONTH				MONTH											
				JAN	FEB	MAR	APR	MAY	JUN	JUL	AUG	SEP	OCT	NOV	DEC
2005	2009	2013	2017	A	B	C	D	E	F	G	H	J	K	L	M
2006	2010	2014	2018	N	P	Q	R	S	T	U	V	W	X	Y	Z
2007	2011	2015	2019	a	b	c	d	e	f	g	h	j	k	l	m
2008	2012	2016	2020	n	p	q	r	s	t	u	v	w	x	y	z

\*This date code will be cycled every four years

**Production location: Taiwan**

**■ SUGGESTED REFLOW PROFILE**

Total time : 200 sec. Max.

Solder melting point : 220 °C

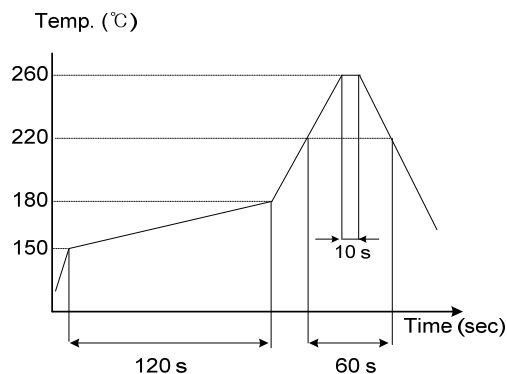

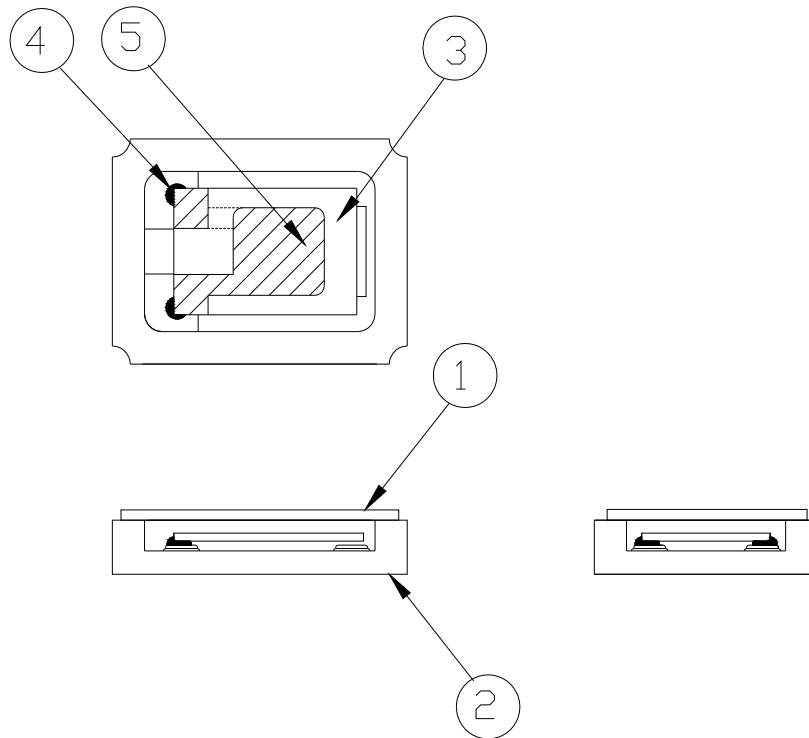
**■ STRUCTURE ILLUSTRATION**

NO	COMPONENTS	MATERIALS	FINISH/SPECIFICATIONS
1	Lid	Kovar	-
2	Base(Package)	Ceramic (Al <sub>2</sub> O <sub>3</sub> )+Pad(Au)	Alumina ceramics
3	Crystal blank	SiO <sub>2</sub>	-
4	Conductive adhesive	Ag	Silicone resin
5	Electrode	Noble Metal	-

PACKING

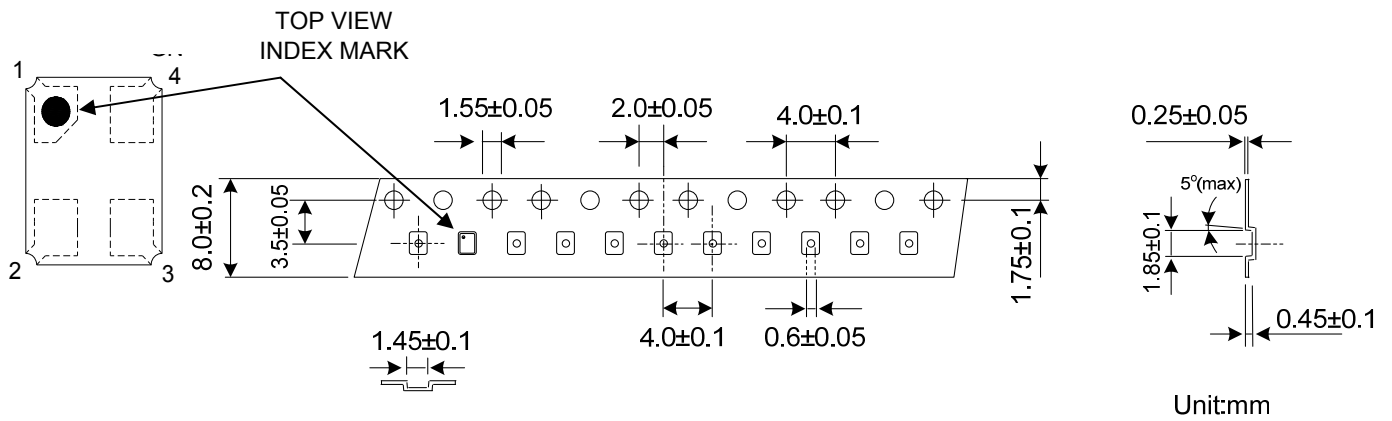

Unit:mm

REMARK :

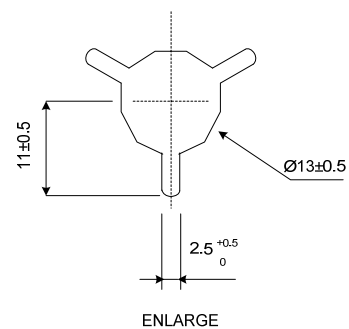
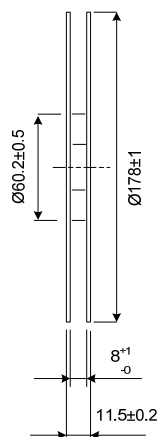
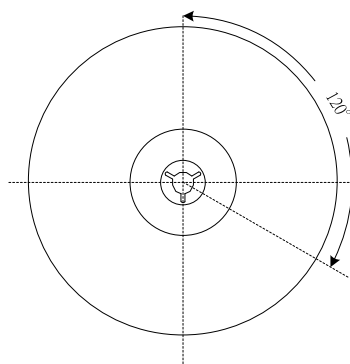
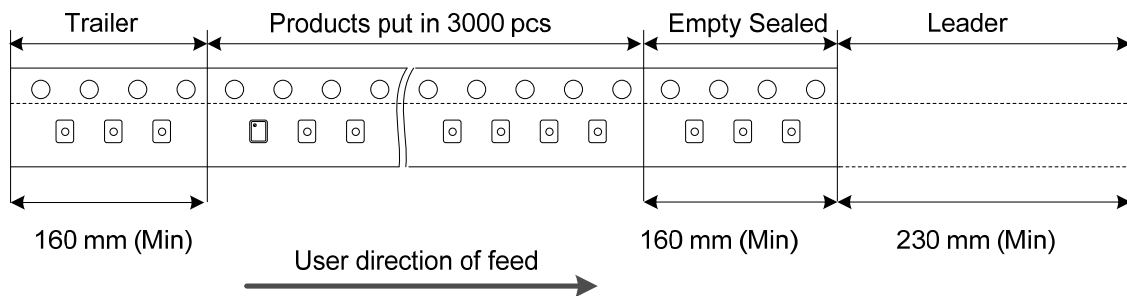

## ■ RELIABILITY SPECIFICATIONS

### 1.Mechanical Endurance

No.	Test Item	Test Methods	REF.DOC
1.1	Drop Test	150 cm height, 3 times on concrete floor.	MIL-STD-202
1.2	Mechanical Shock	Device are shocked to half sine wave ( 1000 G ) three mutually perpendicular axes each 3 times. 0.5m sec. duration time	MIL-STD-202
1.3	Vibration	Frequency range                      10 ~ 2000 Hz Amplitude                                1.52 mm/20G Sweep time                                20 minute perpendicular axes each test time 4 hours (Total test time 12 hours)	MIL-STD-883
1.4	Gross Leak	Standard Sample For Automatic Gross Leak Detector, Test Pressure: 2Kg / cm <sup>2</sup>	MIL-STD-883
1.5	Fine Leak	Helium Bombing 4.5 Kg/ cm <sup>2</sup> for 2 hr	
1.6	Solder ability	Temperature                              245 °C ± 5°C Immersing depth                        0.5 mm minimum Immersion time                         5 ± 1 seconds Flux    Rosin resin methyl alcohol solvent ( 1 : 4 )	MIL-STD-883

### 2.Environmental Endurance

No.	Test Item	Test Methods	REF. DOC
2.1	Resistance To Soldering Heat	Pre-heat temperature                125 °C Pre-heat time                            60 ~ 120 sec. Test temperature                        260 ± 5 °C Test time                                  10 ± 1 sec.	MIL-STD-202
2.2	High Temp. Storage	+ 125 °C ± 3 °C for 500 ± 12 hours	MIL-STD-883
2.3	Low Temp. Storage	- 40 °C ± 3 °C for 500 ± 12 hours	
2.4	Thermal Shock	Total 100 cycles of the following temperature cycle 	MIL-STD-883
2.5	High Temp & Humidity	85°C ± 3°C, RH 85% , 500Hrs	EIA-JESD22
2.6	Pressure Cooker Storage	121 ± 3°C , RH100% , 2 bar , 240Hrs	EIA-JESD22