

# SPECIFICATION FOR APPROVAL

CUSTOMER : \_\_\_\_\_

PRODUCT TYPE : SMD Crystal 1.6×1.2

NOMINAL FREQ. : 37.400000MHz

TXC P/N : 8Q37470001

REVISION : A6

CUSTOMER P/N : \_\_\_\_\_

PM / SALES : \_\_\_\_\_

DATE : \_\_\_\_\_

CUSTOMER SIGNATURE & Date \_\_\_\_\_

\_\_\_\_\_

- (1) TXC requires one copy returned with signature and title of authorized individual that signifies acceptance of the attached specifications.
- (2) Orders received and accepted by TXC after return of signed copy of specification will be produced per these specifications.
- (3) Any changes to these specifications must be agreed upon by both parties and new revision of the Product Specification Sheet will be issued.
- (4) Any issuance of purchase order prior to consigning back the Approval page of "Specification Sheets" from customers will be regarded as the agreement on the contents of these specifications.

Attachment: Product Specification Sheet

- 1
- 2
- 3
- 4
- 5

**RoHS Compliant**



# TXC CORPORATION

4F, NO. 16, Sec. 2 Chung Yang S Rd., Peitou, Taipei, Taiwan.

TEL : 886-2-2894-1202 , 886-2-2895-2201 FAX : 886-2-2894-1206 , 886-2-2895-6207

www.txccorp.com



## PRODUCT SPECIFICATION SHEET

PRODUCT TYPE : SMD Crystal 1.6×1.2

NOMINAL FREQ. : 37.400000MHz

TXC P/N : 8Q37470001

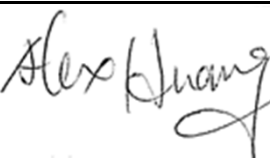
REVISION : A6

PE/RD	QA	MFG
		
Mike Chiu	Alex Huang	Rick Lo
27-Feb-15	27-Feb-15	27-Feb-15

### NOTE:

- (1) The green product standard set by TXC is based upon the international standards. Related information is publicly described on the TXC's Website, and updated regularly. The document is compliant with the latest green product quality system directives at the time.
- (2) Revision "Sx" is for engineering samples only. PE/RD's approval required.
- (3) Revision "Ax" is production ready. PE, QA and MFG's approval required.

**RoHS Compliant**



## ■ ELECTRICAL SPECIFICATIONS

### Standard atmospheric conditions

Unless otherwise specified, the standard range of atmospheric conditions for making measurement and tests are as follow:

Ambient temperature :  $25 \pm 10^{\circ}\text{C}$   
 Relative humidity : 40%~70%

If there is any doubt about the results, measurement shall be made within the following limits:

Ambient temperature :  $25 \pm 3^{\circ}\text{C}$   
 Relative humidity : 40%~70%

### Measure equipment

Electrical characteristics measured by HP E5100A or equivalent.

### Crystal cutting type

The crystal is using AT CUT (thickness shear mode).

### Unit Weight:

0.0029 $\pm$ 0.0010 g/pcs

	Parameters	Symbol	Electrical Spec.				Notes
			Min.	Typ.	Max.	Units	
1	Nominal Frequency	FL	37.400000			MHz	-
2	Oscillation Mode	-	Fundamental			-	-
3	Load Capacitance	CL	16			pF	-
4	Frequency Tolerance	-	$\pm 10$			ppm	at $25^{\circ}\text{C} \pm 3^{\circ}\text{C}$
5	Frequency Stability	-	$\pm 10$			ppm	Over Operating Temp. Range (Reference $25^{\circ}\text{C}$ )
6	Operating Temperature	-	-30	~	85	$^{\circ}\text{C}$	-
7	Aging	-	$\pm 3$			ppm	1st Year
8	Drive Level	DL	-	50	200	$\mu\text{W}$	-
9	Equivalent Series Resistance	ESR	-	-	60	$\Omega$	-
10	Shunt Capacitance C0	C0	-	0.45	2.0	pF	-
11	Motional Capacitance C1	C1	-	1.4	5.0	fF	-
12	Insulation Resistance	-	500	-	-	M $\Omega$	at DC 100V
13	Storage Temperature Range	-	-40	~	85	$^{\circ}\text{C}$	-

**■ DIMENSIONS**

(Unit:mm)

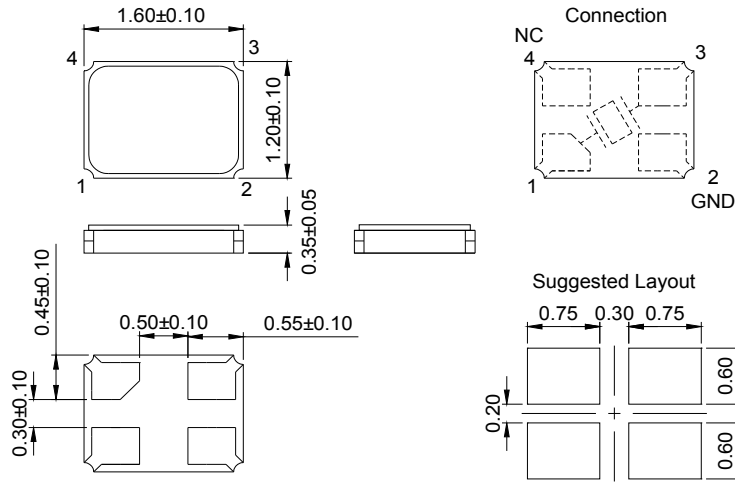

**■ MARKING**

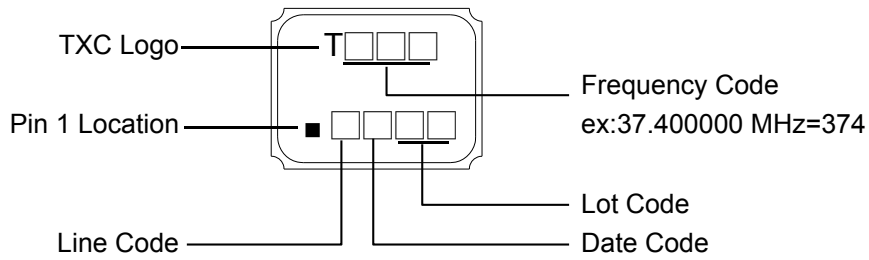

**Date Code:**

		MONTH				YEAR																	
		JAN	FEB	MAR	APR	MAY	JUN	JUL	AUG	SEP	OCT	NOV	DEC										
2005	2009	2013	2017	A	B	C	D	E	F	G	H	J	K	L	M								
2006	2010	2014	2018	N	P	Q	R	S	T	U	V	W	X	Y	Z								
2007	2011	2015	2019	a	b	c	d	e	f	g	h	j	k	l	m								
2008	2012	2016	2020	n	p	q	r	s	t	u	v	w	x	y	z								

\*This date code will be cycled every four years

**Production location: Taiwan**

**■ SUGGESTED REFLOW PROFILE**

Total time : 200 sec. Max.

Solder melting point : 227 °C

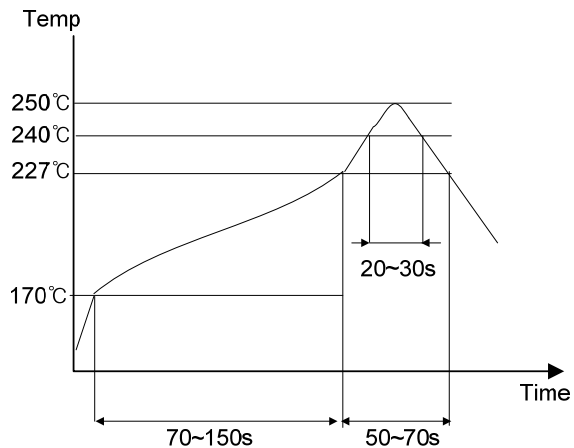

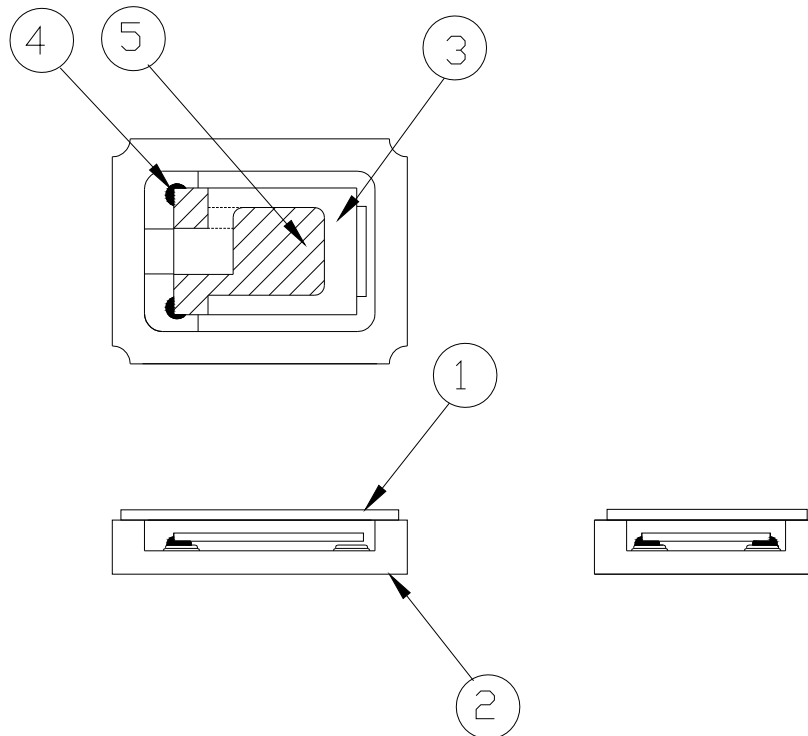
**■ STRUCTURE ILLUSTRATION**

NO	COMPONENTS	MATERIALS	FINISH/SPECIFICATIONS
1	Lid	Kovar	-
2	Base(Package)	Ceramic (Al <sub>2</sub> O <sub>3</sub> )+Pad (Au)	Alumina ceramics
3	Crystal blank	SiO <sub>2</sub>	-
4	Conductive adhesive	Ag	Silicone resin
5	Electrode	Noble Metal	-

■ PACKING

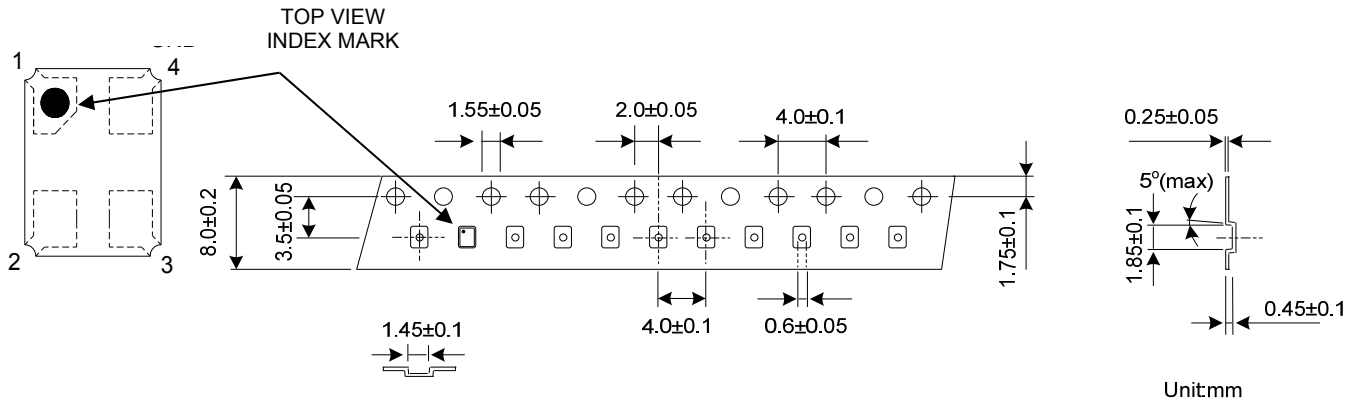

REMARK :

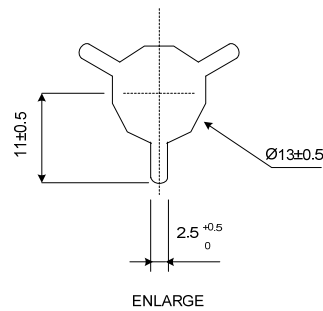
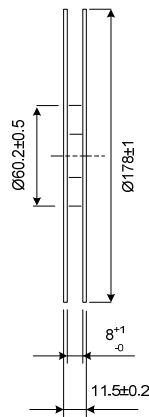
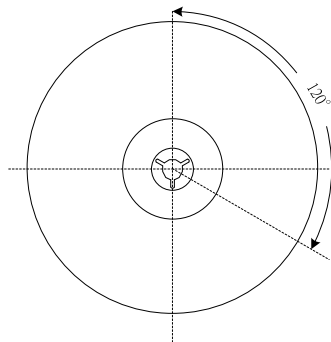
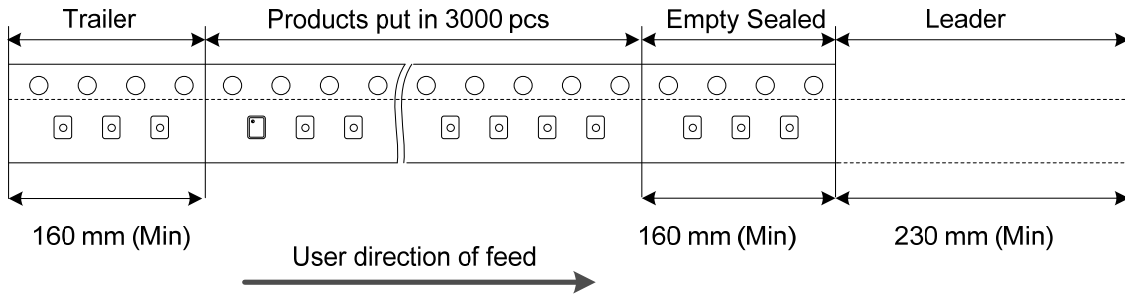

## ■ RELIABILITY SPECIFICATIONS

### 1. Mechanical Endurance

No.	Test Item	Test Methods	REF.DOC
1.1	Drop Test	150 cm height, 3 times on concrete floor.	MIL-STD-202
1.2	Mechanical Shock	Device are shocked to half sine wave ( 1000 G ) three mutually perpendicular axes each 3 times. 0.5m sec. duration time	MIL-STD-202
1.3	Vibration	Frequency range                      10 ~ 2000 Hz Amplitude                                  1.52 mm/20G Sweep time                                20 minute perpendicular axes each test time 4 hours (Total test time 12 hours)	MIL-STD-883
1.4	Gross Leak	Standard Sample For Automatic Gross Leak Detector, Test Pressure: 2Kg / cm <sup>2</sup>	MIL-STD-883
1.5	Fine Leak	Helium Bombing 4.5 Kg/ cm <sup>2</sup> for 2 hr	
1.6	Solder ability	Temperature                              245 °C ± 5°C Immersing depth                        0.5 mm minimum Immersion time                         5 ± 1 seconds Flux    Rosin resin methyl alcohol solvent ( 1 : 4 )	MIL-STD-883

### 2. Environmental Endurance

No.	Test Item	Test Methods	REF. DOC
2.1	Resistance To Soldering Heat	Pre-heat temperature                  125 °C Pre-heat time                              60 ~ 120 sec. Test temperature                         260 ± 5 °C Test time                                      10 ± 1 sec.	MIL-STD-202
2.2	High Temp. Storage	+ 125 °C ± 3 °C for 500 ± 12 hours	MIL-STD-883
2.3	Low Temp. Storage	- 40 °C ± 3 °C for 500 ± 12 hours	
2.4	Thermal Shock	Total 100 cycles of the following temperature cycle 	MIL-STD-883
2.5	High Temp & Humidity	85°C ± 3°C, RH 85% , 500Hrs	EIA-JESD22
2.6	Pressure Cooker Storage	121 ± 3°C , RH100% , 2 bar , 240Hrs	EIA-JESD22